

# ERGO S

USER'S OPERATION MANUAL

04/2024

[www.hetronic.com](http://www.hetronic.com)

## Table of Contents

1. Safety .....	4
1.1 Intended Use .....	4
1.2 Symbol Notation .....	4
1.3 Practices and Laws .....	4
1.4 Required Operator Training .....	4
1.5 Possible Sources of Danger .....	4
1.6 Protective Features .....	5
1.7 STOP in case of EMERGENCY .....	5
1.8 Caring for your ERGO S .....	5
2. Introduction and Functional Description .....	6
2.1 Production and System Numbers .....	6
2.2 Before Operating Your Wireless Control Unit .....	6
2.3 Unit Labels .....	6
3. Your ERGO S Transmitter .....	7
3.1 General Description .....	7
3.2 ERGO S Basic Features .....	7
3.3 Standard ERGO S 2.4GHz Configuration .....	7
4. Operating Your Transmitter .....	9
4.1 Holding Your Transmitter .....	9
4.2 Visually Checking Your Transmitter .....	9
4.3 Powering Up and Starting Your Transmitter .....	9
4.4 Transmitter Initialization with Standard Status LED Indicator .....	9
4.5 Transmitter Initialization with Graphic User Interface (TFT) and Standard Status LED Indicator .....	9
4.6 Turning OFF the Transmitter and Stopping the Radio Remote Control .....	9
4.7 LED Behaviour and Meanings .....	10
4.8 Battery Level Indication .....	10
4.9 Magnetic Belt Clip (if equipped) .....	11
4.10 Cable Control (optional) .....	11
4.11 Start-Up Sequences .....	11
4.12 Front Switch LED .....	11
5. Configuring Your ERGO S .....	12
5.1 Entering Service Mode .....	12
5.2 Adjusting Settings in Service Mode .....	12
6. Theory of Operation .....	18
6.1 Stop Function .....	18
7. ERGO S Battery .....	19
7.1 Recharging your Batteries .....	19
7.2 Charging Unit with Grippers .....	20
7.3 Charging Unit with Slider .....	21
7.4 Battery Disposal .....	22
7.5 Prolonged Battery Life .....	23
8. Troubleshooting .....	24
9. Specifications .....	25
10. Warranty, Service, Repairs and Maintenance .....	26
11. Regulatory Information .....	27
11.1 Europe .....	27
11.2 North America .....	27
11.3 Industry Canada (IC/ISED) Statement .....	28
Appendix A .....	29
Definition of terms .....	29
Appendix B .....	30
B.1 Operator Safety Basics .....	30
B.2 Safety Checklist .....	30
B.3 ERGO S Variants and Current Rating .....	31
Appendix C .....	33
C.1 Spare Parts .....	33

## List of Figures

<b>Figure 1.</b>	Blank Rating Plate.....	6
<b>Figure 2.</b>	ERGO S Transmitter (Right, Front, Left).....	8
<b>Figure 3.</b>	Status and Feedback LEDs.....	8
<b>Figure 4.</b>	Stop Screen .....	10
<b>Figure 5.</b>	Pages 1 and 2 of the Device Settings menu .....	12
<b>Figure 6.</b>	Radio Settings menu .....	12
<b>Figure 7.</b>	Button Diagnostic page on Transmitter.....	13
<b>Figure 8.</b>	Options found under General Settings menu .....	14
<b>Figure 9.</b>	Adjusting TFT Brightness .....	14
<b>Figure 10.</b>	Making Changes to the Access Code .....	14
<b>Figure 11.</b>	Information provided in the 'About' screen .....	15
<b>Figure 12.</b>	Pages 1 and 2 of the Service Mode menu showing Address Learn function .....	16
<b>Figure 13.</b>	Address Learn page .....	16
<b>Figure 14.</b>	Initiating Learning page .....	16
<b>Figure 15.</b>	ERGO S changing channel notification.....	17
<b>Figure 16.</b>	Successful Address Learn notification .....	17
<b>Figure 17.</b>	Inserting the Battery .....	19
<b>Figure 18.</b>	Charging the ERGO S Battery.....	19
<b>Figure 19.</b>	Bench-top or wall-mount variations.....	20
<b>Figure 20.</b>	Pressing the gripper downwards.....	20
<b>Figure 21.</b>	Pressing the clip inwards.....	20
<b>Figure 22.</b>	Pulling the gripper upwards whilst keeping the clip pressed.....	21
<b>Figure 23.</b>	Docking station with slider .....	21
<b>Figure 24.</b>	Slider extension and retraction as ERGO S is inserted .....	22

## List of Tables

<b>Table 1.</b>	ERGO S Transmitter features.....	8
<b>Table 2.</b>	Status LED Behaviour and Meanings .....	10
<b>Table 3.</b>	Start-Up Sequences .....	11
<b>Table 4.</b>	Troubleshooting tips .....	24
<b>Table 5.</b>	Transmitter Technical Specification .....	25
<b>Table 6.</b>	Battery Pack Technical Specification .....	25

# 1. Safety

## 1.1 Intended Use

Your radio remote control is designed for remote operation of machines and systems using safe wireless communications technology. Any modification, reconstruction or extension of the systems without a written agreement of Hetronic may lead to the loss of your warranty and guarantee claims.

Hetronic assumes no liability for damages resulting out of the non-observance of this operating manual. All persons, working with this radio remote control must



- Be suitably trained and qualified as required by the safety regulations.
- Strictly comply with the contents of this operating manual.

Before starting the radio remote control you must have read and fully understood this operating manual. The Safety Checklist in Appendix B is intended to be followed before each time the transmitter is powered up for operation.

## 1.2 Symbol Notation

The following symbols are used in this operating manual. The safety alert symbol is used in decals on the unit and with proper operation procedures in this manual.

Understand the safety message. It contains important information about personal safety on or near the unit.

	<p><b>STOP!</b> This symbol gives you warning of imminent danger of life, risk of accident and risk of injury, as well as damage to property in case of non-observance of the working instructions.</p>
	<p><b>ATTENTION!</b> This symbol advises against a possible damage to the system in case of non-observance of the working instructions.</p>
	<p><b>TIP!</b> This symbol points to features and information which allow for an easier handling or operation.</p>

## 1.3 Practices and Laws

Practice safe working precautions for the benefit of yourself and others.

Be alert to unsafe conditions and the possibility of minor, moderate, or serious injury or death. Learn applicable rules and laws in your area.

## 1.4 Required Operator Training

The original purchaser of this unit was instructed by the seller on safe and proper operation. If unit is to be used by someone other than original purchaser; loaned, rented or sold, ALWAYS provide this manual and any needed safety training before operation. ALWAYS read and understand the documentation for any machine to be controlled by radio remote control.

## 1.5 Possible Sources of Danger

This device is part of a system that makes remote control via wireless radio signals possible. The transmission of control commands can take place around obstacles and out of the operator's direct line of sight. Take the following precautions to prevent accidental start-up and possible injury or damage:



Switch "OFF" the transmitter when it is not in use. Unless the transmitter has user access control password configured, remove the battery if unit is placed away from the operator.



Disconnect the power supply from the receiver before any assembly, maintenance or repair work is done.



**AVOID SYSTEM DAMAGE - ALWAYS** disconnect receiver power supply and control wiring before welding on any part of the machine.



Never remove or alter any of the safety features.



**ALWAYS** confirm that the machine and radio remote control Stop functions work properly **BEFORE** beginning any machine operation.

## 1.6 Protective Features

This transmitter is equipped with electronic and mechanical safety features. Control signals from other transmitters cannot be processed because transmission coding is unique to each system.

## 1.7 STOP in case of EMERGENCY

Push the emergency stop on the machine.

## 1.8 Caring for your ERGO S

The enclosure materials employed on the ERGO S transmitter have been carefully selected to minimise maintenance requirements.



**Buy a Hetric ERGO S holster and screen protector.** These will take care of your transmitter by preventing it from being subject to knocks and scratches. This helps to keep the unit's appearance longer and may also protect it from some internal damage should you accidentally knock or drop it.



**Always use genuine chargers and accessories.** Cheaper ones that are not compatible or made for going with your ERGO S can harm the unit or lessen its lifespan.

Do not keep your ERGO S stored in a closed container for extended periods of time unless it is powered off and the battery is removed from the unit. Charging the ERGO S in a closed container is a potential fire hazard and may shorten its lifespan. Lithium-Ion batteries give off heat when charging and when discharging. Keep your battery percentage between 40%-80% for longer battery life.



**Clean your ERGO S regularly.** Use damp cloth or alcohol wipes to clean the unit's exterior surfaces. Do not use aggressive cleaning agents that may inadvertently damage the unit.

## 2. Introduction and Functional Description

We congratulate you on the purchase of your new Hetriconic ERGO S push button transmitter. You have chosen a high quality product. Familiarise yourself with the unit before using it for the first time. In addition please carefully refer to the operating instructions and the safety advise given in this manual. Only use the product as instructed and only for the intended field of application. Keep these instructions in a safe place. If you pass the product on to anyone else, please ensure that you also pass on all the documentation with it.

### 2.1 Production and System Numbers

Before contacting your dealer or Hetriconic about service, repair or replacement parts, note the equipment Production and System numbers. These numbers are located on the silver label affixed to the unit.

### 2.2 Before Operating Your Wireless Control Unit

Confirm that installation of all your system components has been properly completed. Before start up, **ALWAYS** confirm that the machine and radio remote control Stop functions work properly.

Understand all Safety Precautions provided in the manuals and review control functions and operation of the machine and this radio remote control system. When not in use, turn the transmitter off and store in a safe place to prevent unauthorized use. Ensure that the USB Dongle (which acts as a security key to program the transmitter) is kept in a separate but safe and secure place. If the machine does not respond properly, immediately stop operation. Turn off the transmitter and report the condition to your supervisor.

Turn off the transmitter before any maintenance work is done. Always have fresh batteries on hand or an optional rechargeable battery pack in the battery charger to ensure the availability of a fully charged battery. Installation, setup and service must be performed by authorized and qualified personnel only.

### 2.3 Unit Labels

#### 2.3.1 Blank Rating Plate

1. Specific approvals, such as CE, FCC, IC, etc.
2. Type of ERGO S transmitter
3. Eleven-digit Production Number
4. Eleven-digit System Number
5. Frequency information
6. Current consumption
7. Supply voltage

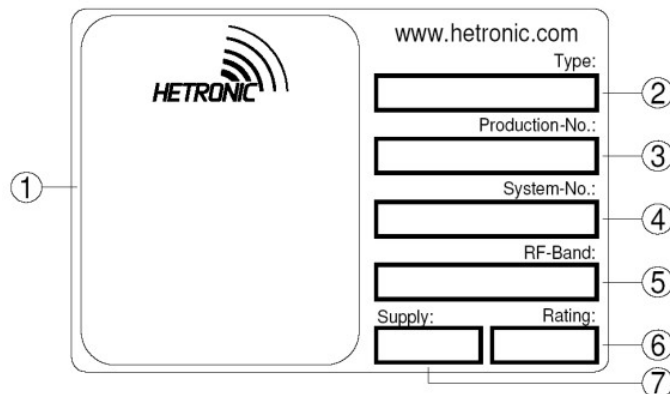

Figure 1. Blank Rating Plate

#### 2.3.2 Read User Manual



The "Read User Manual" symbol on the transmitter acts as a reminder for the user to thoroughly read through the manual before attempting to operate the system. The User Manual must always be placed in a safe and easily accessible place when not being used for when there is the need to refer to it.

## 3. Your ERGO S Transmitter

### 3.1 General Description

The ERGO S is an ergonomically designed, programmable wireless industrial transmitter for remote machine control.

Your transmitter is encased in a rugged IP65 rated housing, is battery-powered, and comes equipped with built-in low battery detection. Standard equipment includes two 3.45Ah Lithium-Ion batteries and battery charger.

### 3.2 ERGO S Basic Features

- Fully programmable via Hetricon PC-Link
- 8 push buttons with up to two detents
- 4 push buttons with single detent, one of which is the power button
- 1 proportional Joystick or Digital Selector Switch
- Minimum 100 m (300 ft.) range using CS4XX and CS8xx modules
- Minimum 60 m (196 ft.) range using CS2400 RF module
- Typically 100 m (300 ft.) range using on board MFS 2G4 radio
- Internal Antenna
- Auto power off feature (configurable)
- Infrared (configurable)
- USB Interface
- Low Battery detection
- Status bi-colour LED Red/Green
- Feedback LEDs bi-colour Red/Green
- Cable Control
- Magnetic Belt Clip
- Data Logging (configurable)
- Rechargeable battery pack

### 3.3 Standard ERGO S 2.4GHz Configuration

Your ERGO S 2.4GHz transmitter is factory programmed to one of the following switch configurations:

#### A. ERGO S 2.4GHz-V1

- 11 Single detent pushbutton
- 1 Single detent POWER pushbutton
- 1 Joystick or Selector Switch

#### B. ERGO S 2.4 GHz-V2

- 3 Single detent pushbuttons
- 8 Double detent pushbuttons
- 1 Single detent POWER pushbutton
- 1 Joystick or Selector Switch



Figure 2. ERGO S Transmitter (Right, Front, Left)

An optional 2.4" 240x320 TFT screen provides real-time visual information during operation of the ERGO S transmitter. It is used to change configuration settings, provide two-way feedback and display transmitter diagnostic information such as battery life, signal strength and button status. The status and feedback LEDs have the same positioning when the TFT is also present on the transmitter.

Feature #	Description
1-8	Up to 2 Detent Momentary Pushbutton (S2-S9)
9-11	Single Detent Momentary Pushbutton (S10-S12)
12	Single Detent Power/Start Pushbutton (S1)
13	Joystick or Selector Switch (S13)
14	Infra Red
15	STOP Pushbutton (S0)
16	USB Port
17	TFT Display
18	Status bi-colour Red/Green LED
19	LED Feedback bi-colour Red/Green (L1-L3)
20	Customised Logo Area
21	Battery Compartment
22	Magnetic Belt Clip

Table 1. ERGO S Transmitter features

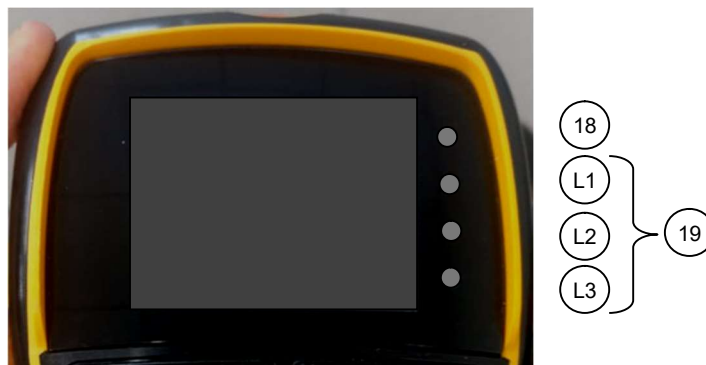

Figure 3. Status and Feedback LEDs



## 4. Operating Your Transmitter

### 4.1 Holding Your Transmitter

Hold the transmitter upright with the front facing you. Confirm that you are able to easily read and understand any operation text or symbols. Complete the following procedures once a day, before the start of an operation and at all shift changes.

### 4.2 Visually Checking Your Transmitter

Always check the transmitter for any physical damage before any operation. Check equipment for wear or damage and confirm that you can read and understand all of the safety labels. Never operate a transmitter with worn out or damaged parts.

### 4.3 Powering Up and Starting Your Transmitter

NOTE: When the transmitter is not being used by the operator, it must be stored in a safe place.

1. Confirm that all safety measures required by the equipment manufacturer have been followed.
2. Insert a fully charged battery into the battery compartment of the transmitter.
3. Insert the USB key supplied with the transmitter in the ERGO S port (#16) and press Power (#12) button to power ON the transmitter unit.
4. Enter Access code (if enabled in Hetronic PC-Link configuration).
5. Power ON the receiver and press **START** (#12) on the transmitter unit to start and enable communication. The transmitter will perform a routine initialization upon start up.

### 4.4 Transmitter Initialization with Standard Status LED Indicator

Upon turning the transmitter ON, all four front LEDs light up as solid colours and then switch off before the unit performs the routine initialization.

During initialization, if the coder finds an error in the radio module, address, configuration or feedback, the transmitter will boot up and the failure will be displayed as a blinking ORANGE (RED and GREEN simultaneously) status LED (#18) at the baud rate. The transmitter may then be connected to Hetronic PC-Link (refer to Programming and Servicing Manual for instructions) for the Error to be corrected.

After a successful initialization, the ERGO S transmitter will enter Normal Operation Mode. The Green LED (#18) will blink at the baud rate i.e. the LED toggles on with every transmitted telegram frame. All other LEDs switch off. Test all machine functions. Refer to your machine, transmitter and receiver documentation as needed.

### 4.5 Transmitter Initialization with Graphic User Interface (TFT) and Standard Status LED Indicator

Upon turning the transmitter ON, the TFT screen turns ON and all the front LEDs light up as solid colours and then switch off before the unit performs the routine initialization.

During initialization, if the coder finds an error in the radio module, address, configuration or feedback, the transmitter will boot up and the failure will be displayed as a blinking ORANGE (RED and GREEN simultaneously) status LED (#18) at the baud rate. The error will also be displayed on the screen. The transmitter may then be connected to Hetronic PC-Link (instructions can be found in Programming and Service Manual) for the Error to be corrected.

After a successful initialization, the ERGO S transmitter will enter Normal Operation Mode and display the splash screen. The correct Operation Access Code must be inputted for the ERGO S to start operating, if this is enabled through Hetronic PC-Link configuration.

NOTE: This can be changed/enabled/disabled when the transmitter is in Service mode during operation or through Hetronic PC-Link. Refer to Section 5.1 for instructions on how to change when in Service Mode and in Programming and Service Manual for Hetronic PC-Link instructions.

The basic home screen will then be displayed and the Green LED (#18) will also blink at the baud rate i.e. the LED toggles on with every transmitted telegram frame. All other LEDs switch off. Test all machine functions. Refer to your machine, transmitter and receiver documentation as needed.

### 4.6 Turning OFF the Transmitter and Stopping the Radio Remote Control

Below are the steps to follow to turn off the transmitter:

1. Press the **STOP** button (#15).

The **STOP screen** appears, the RED status LED blinks at a fast rate and the transmitter sends a Stop telegram to the receiver. Upon receiving the Stop telegram, the receiver goes into Safe Mode and turns OFF all receiver outputs.



Figure 4. Stop Screen

2. Press the **Start** button (#12) and the Shut Down Delay timer starts. The transmitter shuts off once the delay timer is over. This is normally set to 2 seconds by default but can be programmed differently (refer to Programming and Service Manual). The OFF state of the LED indicates that the transmitter has switched off. If the Start/Power button is not pressed the Transmitter does not switch OFF.

Note: If the user wishes to resume operation, this is possible by deactivating the STOP switch.



WARNING: Holding the transmitter improperly while operating your machine could result in unexpected machine response.



WARNING: Test the stop function as described in the machine manufacturer's operator manual before beginning any operation.



WARNING: To avoid accidental start-up, always press STOP when not in use.

Turn OFF your machine if there is a fault or problem with the safety check.

NEVER operate the machine if the STOP function does not work properly.



WARNING: Improper operation, maintenance or adjustment may cause serious injury or damage to equipment and may void the warranty.

#### 4.7 LED Behaviour and Meanings

The following table gives the meanings for the different behaviours of the Status LED (#18).

Result	Meaning
Red & Green LED turns ON always.	Service Mode.
Green LED Blinks.	Data is being transmitted.
Red LED Blinks.	Battery low.
Red LED Blinks at fast rate.	Stop switch active. Stop Data is being transmitted.
Red & Green LED Blinks.	H-link data transmitted to PC application.
Red & Green LED Blinks at fast rate.	Boot loader mode to update the firmware.
Red & Green LED Blinks.	FB / RF / Address / Configuration Error on Startup.

Table 2. Status LED Behaviour and Meanings

The other three bi-colour LEDs (#19) are configurable through H-Link and are typically used as feedback signals.

#### 4.8 Battery Level Indication

Unless the transmitter is equipped with a TFT screen, in which case the Battery Level is also displayed on the status bar, the transmitter uses two different warning signs to show the user that the battery needs replacement.

When the Low Battery level warning has been triggered, the RED status LED (#18) will blink at the baud rate.

In addition to low battery warning, a fixed critical battery level is also monitored. When critical battery level is reached, the RED Status LED will blink faster. The coder will automatically trigger the Stop telegram for about 5 seconds until it shuts off.

#### 4.9 Magnetic Belt Clip (if equipped)

The practical magnetic belt clip allows the user to hang the ERGO S transmitter to any steel surface and continue operation hands free or store the transmitter hung vertically when not in use and have easy access to it.

#### 4.10 Cable Control (optional)

The ERGO S can also be used either wirelessly or via cable control. When the tether is connected, all wireless communication will be disabled and the telegram will be sent via the cable through the RS232 or CAN bus, depending on the chosen configuration. The tether cable is connected directly to a battery enclosure and this contains a particular module which must be configured via Hetricon PC-Link. Refer to Programming and Service Manual for instructions.

The following standard cable options are available to choose from depending on the application. However, customized variants can also be ordered.

- a) 10m CAN cable without termination jumper (#1051512510)
- b) 10m CAN cable with termination jumper (#1051512610)
- c) 10m RS232 cable (#1051513510)

#### 4.11 Start-Up Sequences

A number of sequences are available which will allow the user to enter different modes during Start-up. Below is a table which outlines these sequences. In each case, the user needs to hold the respective sequence buttons to activate that particular mode.

Mode	Sequence
Normal Operation	Start Switch (#12)
Service Mode	Stop Switch (#15) + Start Switch (#12)+ Top Left Switch (#9)
Copy USB H-Link Settings	Stop Switch (#15) + Start Switch (#12) + Lower Right Switch (#10)
Copy USB Graphics	Stop Switch (#15) + Start Switch (#12) + Lower Left Switch (#11)
Wireless Hetricon PC-Link	Stop Switch (#15): Active only for the initial 5s after Power Up
Shutdown	Stop Switch (#15) + Start Switch (#12)

**Table 3.** Start-Up Sequences

#### 4.12 Front Switch LEDs

If your ERGO S transmitter includes the front switch LEDs feature, the front facing buttons (#1 - #8) will light up when the transmitter is in low light conditions. The buttons will no longer be lit up when the lighting conditions improve. Lighting conditions are detected by the infra red detector (#14).

## 5. Configuring Your ERGO S

When the Transmitter is in Service Mode, certain configuration settings such as: Access code, RF module and Channel Selection, Screen Brightness, Date and Time, TX Baud Rate, and others, may be checked and edited.

**NOTE:** Service Mode is only accessible on transmitters equipped with the optional graphic user interface. The units equipped with the standard status LEDs can only have their settings updated via Hetronic PC-Link tool. Refer to Programming and Service Manual for instructions.

### 5.1 Entering Service Mode

1. Make sure STOP switch (#15) on transmitter is activated.
2. Switch on ERGO S by pressing the Start button (#12) and then keeping the side switches (#9 and #12) pressed until the splash screen disappears and the 'Device Settings' screen appears.
3. Input the 'Service Access' code if this is enabled in the Hetronic PC-Link configuration and perform the appropriate selections.



Figure 5. Pages 1 and 2 of the Device Settings menu

### 5.2 Adjusting Settings in Service Mode

The four topmost buttons on the front panel are used to navigate through Service Mode and also to change setting parameters within the menus. The menu selection changes with every screen and the description of what each of the four buttons will do is explained next to the button number.

**Note:** Once the user exits 'Service Mode' the changes are automatically saved to the USB Key, only if it already contains a settings file. Whenever a USB Key with different configuration settings is inserted in the transmitter, the user is prompted to choose whether the settings on the USB Key are to be saved to the coder ("Copy to Coder") or whether the settings on the coder are to replace the existing ones ("Copy to USB Key").

**Note:** When the USB Key is not detected, a warning message is displayed stating that the key is missing and unit is shutting down.

The user has the possibility of checking or changing the following features or settings directly from the transmitter from the below menus.

#### 5.2.1. Radio Settings Menu

The user has the possibility of checking or changing the Radio Settings directly from the transmitter from the respective menu in Service Mode.

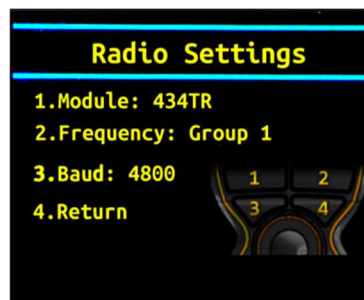

Figure 6. Radio Settings menu

- Frequency Channel or Group

1. Press button #1 to enter Radio Settings menu.
2. Press button #2 to scroll through the list of channels or groups until the desired one is visible.
3. Press button #4 to save selection and return to main 'Device Settings' page.

- Transmitter Baud Rate

The allowable baud rates of the control telegram that may be configured are 4800 or 9600bits/second for the Hetronic standard 4xx-8xx MHz radio modules. The standard baud rate of 115200bits/second is used for Hetronic standard 2.4GHz radio modules. To change the TX Baud Rate when the transmitter is in Service Mode one has to:

1. Press button #1 to enter Radio Settings menu.
2. Press button #3 to scroll through the available baud rates and stop when the desired one is visible.
3. Press button #4 to save selection and return to main 'Device Settings' page.



**The baud rate for the transmitter must be identical to that of the receiver.** Whenever the baud rate of a unit is changed, the baud rate of the paired unit must be changed accordingly.

**Note:** The coder still supports all other baud rates in cases when non-standard radio modules are used.

### 5.2.2. Button Diagnostic Checks

The button diagnostic checks can be carried out directly from the transmitter to ensure that all 1-Step and 2-Step switches are working properly.

1. Press button #2 for Button Diagnostic page from main 'Device Settings' menu.
2. Press any front (1-step or 2-step) or side (1-Step) buttons to test proper functionality.

When pressing the first step of a 2-Step button, the respective diagnostic identifier for that button switches on blue. When the second step is pressed, the identifier will change to green. 1-Step switches will only use the blue identifier. If a button is not functioning well, the diagnostic identifier remains on.



Figure 7. Button Diagnostic page on Transmitter

Once all checks are made, the user can return to the main screen by making sure the STOP button is pressed whilst holding buttons #1 and #2 pressed simultaneously.

### 5.2.3. General Settings

The following settings may be accessed and adjusted from their respective menus as outlined below:



Figure 8. Options found under General Settings menu

- TFT Brightness

TFT brightness can be adjusted between setting 1 and setting 8, with 8 being the brightest.



Figure 9. Adjusting TFT Brightness

1. Press button #3 to enter General Settings menu.
2. Press button #1 to go to Brightness page.
3. Press button #1 to increase brightness or button #2 to decrease brightness.
4. Press button #3 to save the new setting and return to the General Settings menu.

- Operational Access Code

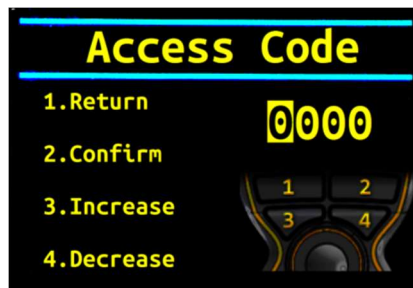

Figure 10. Making Changes to the Access Code

1. Press button #3 to enter General Settings menu.
2. Press button #2 to go to Access Code page.
3. Press button #3 to increment (or button #4 to decrement) the highlighted digit and button #2 to confirm and move on to the next digit.
4. When all the required changes have been made, press button #2 to confirm the new access code.

- Date

1. Press button #3 to enter General Settings menu.
2. Press button #4 to go to next page of General Settings menu.
3. Press button #1 to change Date.

- Time

Time displayed on the status bar of your ERGO S transmitter can only be in 24hrs format. To update the time from the transmitter:

1. Press button #3 to enter General Settings menu.
2. Press button #4 to go to next page of General Settings menu.
3. Press button #2 to change Time.

- Language

The language of the menus in Service Mode can be changed to English, Spanish, French, Italian or German.

1. Press button #3 to enter General Settings menu.
2. Press button #4 to go to next page of General Settings menu.
3. Press button #3 to scroll through the list of available languages.
4. Press button #4 to confirm the selection and return to previous page.

#### 5.2.4. About the Transmitter

- Transmitter, Radio and Software information

Basic transmitter and software information, including address, can be viewed from the 'About' option found in the second page of the 'Device Settings' menu. The number of hours of operation is also shown here.

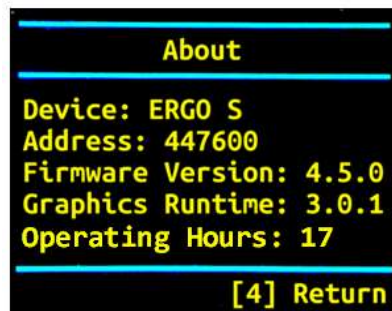

*Figure 11. Information provided in the 'About' screen*

1. Press button #4 to go to second page of Device Settings menu
2. Press button #1 to go to 'About' page.
3. Press button #4 to return to previous page.

#### 5.2.5. Address Learn Function

If your ERGO S transmitter includes an address learn function for quick pairing to a receiver unit, the option will show on Page 2 of the Service Mode menu.

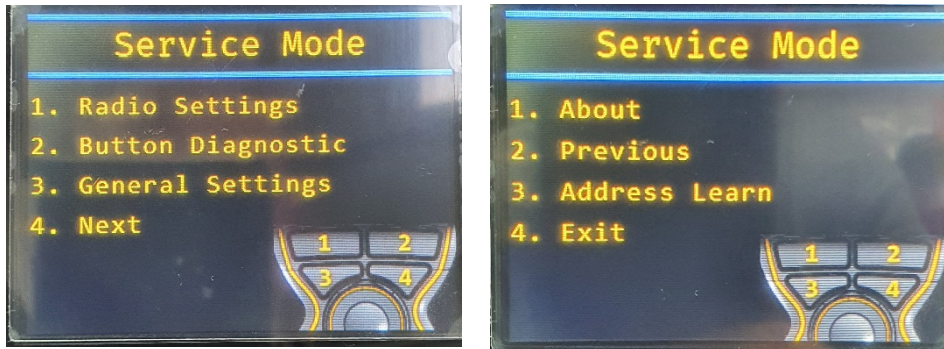

Figure 12. Pages 1 and 2 of the Service Mode menu showing Address Learn function

1. Press button #4 to enter Page 2 of the Service Mode menu.
2. Press button #3 to access the Address Learn function. The following page will be displayed.

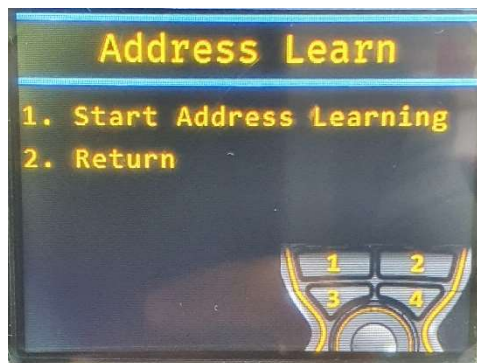

Figure 13. Address Learn page

3. Start the Address Learn function on your machine.



The next few steps will need to be performed within 10 seconds of starting the Address Learn function from the machine. Otherwise, the Address Learn procedure will need to be restarted.

4. On the ERGO S, press and hold button #1 to Start Address Learning. The following page will be displayed.

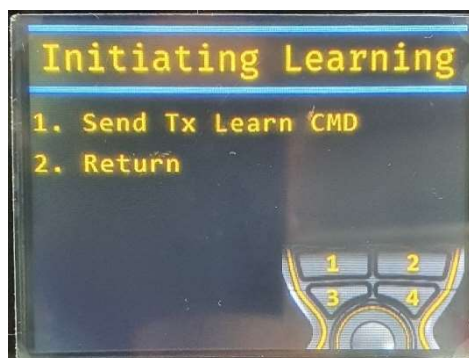
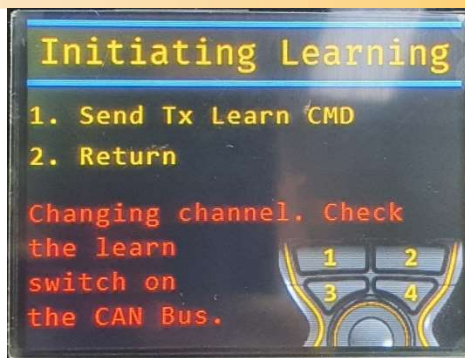

Figure 14. Initiating Learning page

5. Keep holding button #1 to Send Tx Learn Command.
6. If the below notification shows up, it means that the ERGO S is changing its frequency channel to continue trying to detect the receiver on the machine. Keep holding button #1.





**Figure 15.** ERGO S changing channel notification

7. If successful, the following notification will be displayed. You can then stop the Address Learn function from the machine and restart the ERGO S transmitter.

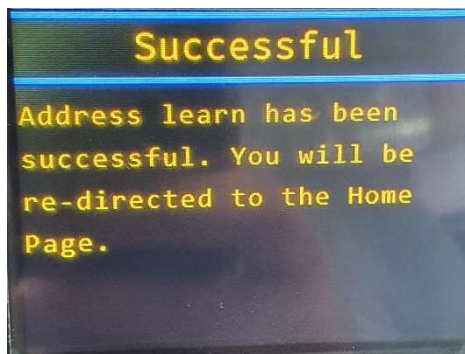

**Figure 16.** Successful Address Learn notification

8. If the above notification does not show after 10 seconds, then you may need to restart the address learn procedure from the beginning.

## 6. Theory of Operation

Your ERGO S transmitter works with a receiving device to transfer machine control commands via radio frequency to your machine. The transmitter electronically generates a carrier frequency that allows it to communicate with the receiver without the use of cables or wires. The receiver then converts the carrier frequency information into discrete machine control outputs that interface with your machine's controls. Each transmitter and receiver that comprises a system is programmed with a unique address code. This code ensures that machine operations are safe, and that other remote control equipment cannot unintentionally control your machine. The receiver only accepts commands from the transmitter with the same address code. The receiver and transmitter have the address code set at the factory.

### 6.1 Stop Function

The most important feature of the radio remote control system is the STOP function. When the transmitter is turned on, it performs a self-test to confirm that communications are within designated parameters. If an error is detected, the transmitter will not transmit any signals. The transmitter sends the STOP pushbutton status along with the specified machine functions. This method confirms that ongoing operations are safe. If the STOP pushbutton (#15) is pressed, the data telegram changes so that only the stop command is transmitted. No other motion command data is sent.

This special data telegram places the receiver in Safe Mode, and the stop relays in the receiver open. All other machine functions are completely disabled in the receiver.

The STOP button (#15) on the transmitter is only a remote stop and will operate only when the transmitter is powered up.



Pressing the STOP pushbutton (#15) does not ensure the machine will come to a complete stop. STOP button functionality is subject to the wiring of receiver STOP relays to machine emergency stop circuit and controlled machine logic where applicable.

ALWAYS test the STOP function at the beginning of every operation session or when there is change of operator.

## 7. ERGO S Battery

You may power your transmitter with a Hetricon ERGO S rechargeable battery inserted into the bottom of the transmitter. Follow the instructions below to ensure best performance of your ERGO S transmitter and prolonged battery lifetime.

1. Confirm that your batteries are fully-charged. See “Recharging Your Batteries” section below.
2. Slide the recharged battery into the battery compartment at the bottom of the transmitter as shown, and snap it into place.

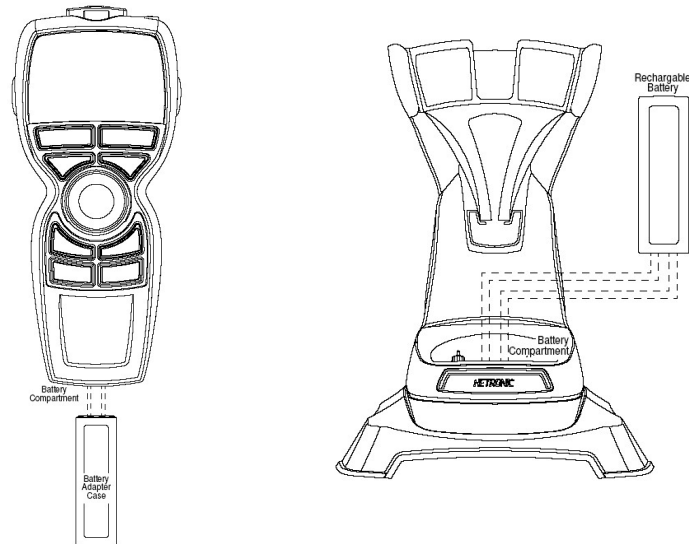

Figure 17. Inserting the Battery



EXPLOSIVE GASES AND FLYING DEBRIS can cause death or serious injury. Use only Hetricon replacement rechargeable batteries. Use of unauthorized replacement batteries could cause a battery explosion resulting in injury or death of the operator or other people in the work area.

### 7.1 Recharging your Batteries

The two methods which can be used to charge the batteries using the ERGO S charging unit are:

- The user can choose to remove the battery from the transmitter and place it directly in the charging unit.
- Else, the user can opt to charge the battery by placing the whole transmitter unit in the charger docking station.



Figure 18. Charging the ERGO S Battery

**NOTE:** When inserting the USB power cable in the transmitter this acts as a power bank, however, does not charge the battery.

**NOTE:** If your charging unit includes a chime function, then the battery can only be charged by docking the ERGO S in the charging station.

When the transmitter (or the battery) is placed in the docking station, the red LEDs flash for two seconds, and then stay lit during the charging process. The red LEDs turn on sequentially as charging progresses. When the battery is fully charged, the green LEDs light up and the red LEDs go off. If the transmitter is placed on the docking station whilst it is still in operation then the transmitter will automatically send a STOP telegram and then will shut down.

Charging time could take up to 3.5 hours, depending on the condition of the battery.

Leave the battery in the charger until it is needed. The charger supplies a “trickle” charge but it will not over-charge the battery.

If the battery is faulty, the red LEDs will blink continuously.

## 7.2 Charging Unit with Grippers

The charger docking station base can be dismantled from the bench-top state to obtain a wall-mount charger instead.

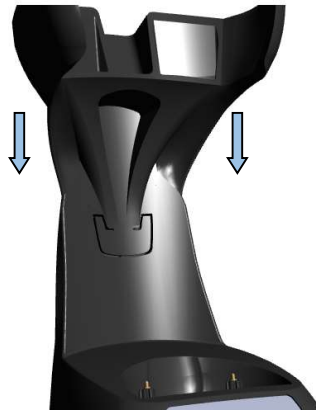

**Figure 19.** Bench-top or wall-mount variations

### 7.2.1 Removing the grippers

In order to obtain the wall-mount version and mount it to a wall/panel, the grippers must be removed by following the below steps:

1. The gripper is to be pressed firmly downwards (towards the charger) until the gap is minimized as much as possible.



**Figure 20.** Pressing the gripper downwards

2. The gripper clip is to be pressed firmly inwards.

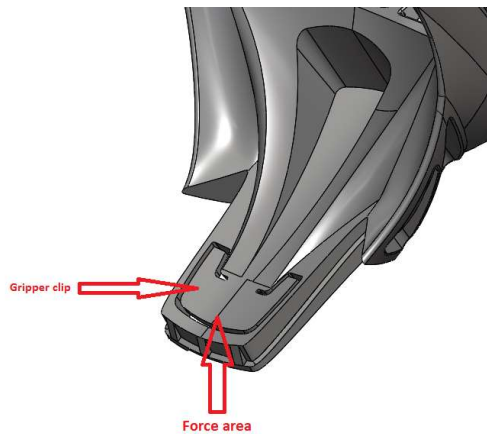

**Figure 21.** Pressing the clip inwards

3. The gripper is to be pulled upwards whilst keeping the clip pressed inwards.

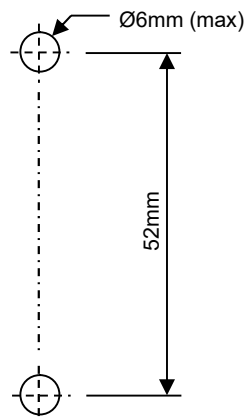

Figure 22. Pulling the gripper upwards whilst keeping the clip pressed

### 7.2.2 Mounting the Charger

To mount the charger to a wall/panel after the grippers have been removed:

1. The location must be defined and two holes aligned vertically 52mm apart must be drilled to accommodate maximum M6 Hex or Allen bolts.



2. Align the drilled holes with the ones in the charger and use the chosen bolts/screws to hang and tighten it in place.

**Note:** When mounting the charger to a panel with hex bolts, the hex bolt head can seat inside the slots available in the charger so that it can be tightened using nuts from behind the same panel.

3. The grippers can then be placed in the charger and pushed downwards until the clip snaps in place.

### 7.3 Charging Unit with Slider

The charger docking station unit with slider does not come with a base, as it is intended to be used as a wall-mount charger only.

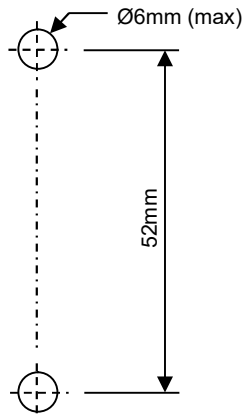

Figure 23. Docking station with slider

### 7.3.1 Mounting the Charger

To mount the charger to a wall/panel:

1. The location must be defined and two holes aligned vertically 52mm apart must be drilled to accommodate maximum M6 Hex or Allen bolts.



2. Insert the slider assembly into the charger, ensuring the holes of both parts align with each other.
3. Align the drilled holes with the ones in the charger and use the chosen bolts/screws to hang and tighten it in place.

**Note:** When mounting the charger to a panel with hex bolts, the hex bolt head can seat inside the slots available in the charger so that it can be tightened using nuts from behind the same panel.

4. Attach the cover provided.

### 7.3.2 Inserting and removing the ERGO S transmitter

1. Angle the top of the ERGO S into the slider from below. Push upwards to extend the slider until the ERGO S clears the bottom of the charger.
2. Gently lower the ERGO S into the charger receptacle, ensuring contact is made with the two large pins on the charger.
3. To remove, grab the ERGO S and push upwards to extend the slider until the ERGO S clears the receptacle.
4. Angle the ERGO S outwards and gently lower it to retract the slider.



**Figure 24.** Slider extension and retraction as ERGO S is inserted

## 7.4 Battery Disposal

AVOID ENVIRONMENTAL POLLUTION. Recycle your rechargeable batteries according to local recycling rules and regulations. If you have questions or problems operating your battery charger, please contact your nearest Hetricon dealer or service center.

Standard Hetricon rechargeable batteries are the Lithium –Ion type. These batteries have no “memory effect” when charging a battery that is not fully discharged.

## 7.5 Prolonged Battery Life

Avoid battery misuse, over charging, overheating or regular dropping. This can cause permanent damage to the cells. Refer to Section 9 (Table 4) for battery specifications.



Never keep a fully charged battery at elevated temperatures. Battery pack does not die suddenly but the runtime gradually shortens as the capacity fades.



Keeping the charge in the 40% to 80% range will prolong battery life.

Unfortunately there is no avoiding fact that battery has a finite life, after which they will certainly degrade. Following these basic tips can help delay the inevitable.

# 8. Troubleshooting

If your ERGO S does not operate after normal start-up, follow the recommended troubleshooting sequence to help isolate the cause and determine corrective action. If you need more information, contact your nearest Hetronic dealer.

PROBLEM	PROBABLE CAUSE	CORRECTION
Transmitter won't start	Incorrect Access code (if enabled)	Enter correct access code
	Battery fully discharged	Replace with fully charged battery if needed
The transmitter is turned on, but does not transmit (Power LED not flashing)	Battery is discharged	Replace battery with a fully charged battery
	Component failure	Contact your supervisor or nearest Hetronic Service Centre
Transmitter is transmitting (Power LED flashing), but machine will not respond	No power to the receiver	Check the diagnostic LEDs in the receiver to be sure power is applied. Ensure that the system is properly grounded
	Transmitter/receiver frequency channels do not match	Follow instructions under "Setting Frequency and channels" or contact your supervisor
	Transmitter out of range	Take the transmitter back into the range of the receiver, press START
	Receiver power off	Turn on power to receiver
	Blown fuse in receiver	Check all fuses and replace if needed
	STOP failure in receiver. Red STOP LED on PC board is illuminated	Contact your supervisor
All machine motions operate intermittently	Receiver antenna connection is loose or missing	Tighten or replace antenna
	External antenna (if used) has loose connection, poor grounding or interference	Tighten antenna and ground connection. Contact Hetronic or your Dealer for more information
	Connector inside receiver is loose	Check all connectors, reseat if needed
	Another frequency may be interfering with the system	Contact your supervisor
USB Key Missing	Missing or damaged USB	Check the USB
	Firmware Update is Needed when a new USB is used on transmitters built before 2024	Contact Hetronic to get the latest firmware and check the instructions (can be found in the Programming and Service Manual) on how to update firmware on the coder

**Table 4. Troubleshooting tips**



# 9. Specifications

<b>Transmitter</b>	
Housing	Ergonomically designed Impact Resistant Polymer Composite
Environmental Protection	IP 65 (Exceeds Nema 12/13)
Weight	~450g (1.21lbs) including battery And full duplex configuration
Dimensions	Height: 240 mm (9.4 in.)
	Width: 110 mm (4.2 in.)
	Depth: 80 mm (3.1 in.)
Antenna	Internal
Power Supply Voltage Range	Battery +B: 3.0 to 5.0Vdc Optional Cable Control +B: 6.5 to 32Vdc Battery Charge: 3.0 to 4.2Vdc
Diagnostics	Status LED for operation and standard/advanced low battery detection
Operation Time	Up to 11 hrs continuous transmission*
Control Configuration	V1 – 11 single detent push buttons, start + stop
	V2 – 8 two detent push buttons, 3 single detent push buttons, start + stop
Frequency Range	4xxMHz or 8xxMHz or 9xxMHz or 2.4GHz (subject to purchased configuration) **
Power (RF Output)	Typically ≤ 10 mW E.I.R.P; depends on country legislation
Typical Operating Range	Typically 120 m. (400 ft.) for ≤ 1GHz, 100m (300ft) for MFS2G4, 50-60m (170 ft) for ≥ 1GHz
Safety	20-bit programmable address concept with up to 1,000,000 combinations
	Hamming Distance 4
Operating Temperature Range	-20°C . . . 70°C (-4°F . . . 158°F)
Storage Temperature Range	-40°C . . . 85°C (-40°F . . . 185°F)
Humidity Range	95% IEC 60068-2-78
Response Time	Less than 100 msec.
Standard Features	Fully programmable via Hetricon PC-Link
	USB (Type A) Interface with 4Gb Memory key for configuration settings
	Status LED for std/adv. low battery detection and Feedback LEDs
	STOP Button EN 60204-1, ISO 13850, IEC60947 Compliant
	User programmable RTC
	Start and Function Interlock
Central control options	User programmable Infrared ACK Start-Up
	Prop Joystick 2-axis
	Selector switch 3 position
TFT	Blank
	240(RGB)*320 2.4" TFT with Backlight Colour 65K/262K Sunlight Readable User-replaceable protection cover

**Table 5. Transmitter Technical Specification**

\*assuming brand new, fully charged battery at 20°C temperature

\*\* for full Channel Lists refer to Frequency Bands Radio Modules Charts

<b>Battery Pack</b>	
Rated Capacity	3.7V, 3400mAh, 0.2C discharging
Storage Environment Conditions	-20°C . . . 45°C, 90%RH max (for short periods less than 1 month) -10°C . . . 45°C, 90%RH max (for long periods more than 3 months) 15°C . . . 35°C, 85%RH max (recommended storage)*
Charging Temperature Range	0°C . . . 45°C (32°F . . . 113°F), max 90%RH
Discharging Temperature Range	-20°C . . . 70°C (-4°F . . . 158°F) , max 90%RH
Charging Time (hrs)	3-4

**Table 6. Battery Pack Technical Specification**

\* for long time storage, the cell's storage voltage should be 3.6-3.9V and it is recommended to charge the cell every six months.

# 10. Warranty, Service, Repairs and Maintenance

Before any service or maintenance intervention on remote controlled equipment always:

- Remove all electrical power from the equipment
- Follow lock out procedures

Hetronic products are covered by a guarantee/warranty against material, construction and manufacturing faults. During the guarantee/warranty period, Hetronic may replace the product or faulty parts. Work under guarantee/warranty must be carried out by Hetronic, or by an authorized service centre specified by Hetronic. Any modification, reconstruction or extension of the systems without a written agreement of Hetronic may lead to the loss of your warranty and guarantee claims.

The following are **not** covered by the guarantee/warranty:

- Faults resulting from normal wear and tear
- Consumables e.g. batteries
- Products that have been subject to unauthorized modifications
- Faults resulting from incorrect installation and use

## **Maintenance and Preventive Care**

- Repairs and maintenance must be carried out by qualified personnel
- Only use original Hetronic spare parts
- Contact your representative for service or any other assistance
- Keep the product in a clean, dry place
- Keep battery contacts clean
- Wipe off dust using a slightly damp, clean cloth
- Keep rubber over-mould clean
- Remove dust from inside gaps, docking recesses and battery contacts using a vacuum. Special care must be taken when cleaning the battery compartment of the transmitter as detachment of the pressure balance element may lead to ingress protection problems

## **NEVER USE:**

- Abrasive cleaning solutions or high-pressure water jets.
- Sharp, pointed objects or any hard items as these may tear the over-mould or rubber parts.
- Compressed air as this may lead to ingress protection issues.
- Petroleum based solvents including Diesel and Gasoline to clean the unit as these may react with the silicone rubber of the joystick gaiter.

# 11. Regulatory Information

## 11.1 Europe

### CE Marking

Hetronic hereby declares that the radio equipment types listed in this manual are in compliance with Directive 2014/53/EU.

The latest version of the complete EU Declaration of Conformity is available on the Hetronic website [www.hetronic.com](http://www.hetronic.com).

### WEEE Directive



This symbol means that inoperative electrical and electronic products must not be mixed with household waste. The European Union has implemented collection and recycling system for which producers are responsible. For proper treatment, recovery and recycling, please dispose of the product in a designated collection point.

### REACH Compliance

Hetronic confirms that, to the best of its knowledge and continual communication with its respective suppliers, chemical Substances of Very High Concern (SVHC) are not included in our products. Based on the response statements of our suppliers no materials from the ECHA are included on Hetronic products. For the latest version of the complete Declaration of Conformity please visit the Hetronic website [www.hetronic.com](http://www.hetronic.com).

### RoHS Compliance

As a designer and manufacturer of electrical and electronic products covered by RoHS and RoHS2, Hetronic confirms that to the best of its knowledge at the date of this statement, none of the products supplied by it contain any of the hazardous substances in excess of permitted levels referred to in the Directive 2002/95/EC. The latest version of the complete Declaration of Conformity is available on the Hetronic website [www.hetronic.com](http://www.hetronic.com).

## 11.2 North America

FCC ID: LW9-ERGOS2G4

### FCC Recommendations:

This device complies with Part 15 of the FCC Rules. Operation is subject to the following two conditions:

1. This device may not cause harmful interference, and
2. This device must accept any interference received, including interference that may cause undesired operation.

Changes or modifications not expressly approved by the manufacturer could void the user's authority to operate the equipment.

To comply with FCC RF exposure compliance requirements, this device and its antenna must not be co-located with, or operating in conjunction with, any other antenna or transmitter.

This equipment has been tested and found to comply with the limits for a Class B digital device, pursuant to Part 15 of the FCC Rules. These limits are designed to provide reasonable protection against harmful interference when the equipment is operated in a residential environment.

This equipment generates, uses, and can radiate radio frequency energy and, if not installed and used in accordance with the instructions, may cause harmful interference to radio communications. However, there is no guarantee that interference will not occur in a particular installation. If this equipment does cause harmful interference to radio or television reception, which can be determined by turning the equipment off and on, the user is encouraged to try to correct the interference by one or more of the following measures:

- Reorient or relocate the receiving antenna
- Increase the separation between the equipment and receiver
- Connect the equipment into an outlet on a circuit different from that to which the receiver is connected.
- Consult the dealer or an experienced radio/TV technician for help.

### 11.3 Industry Canada (IC/ISED) Statement

IC ID: 2119B-ERGOS2G4

#### IC RF Exposure Statement

This device meets the IC requirements for RF exposure in public or uncontrolled environments.

#### IC Warning

This product complies with Industry Canada's licence-exempt RSS standards. Operation is subject to the following two conditions:

1. This device may not cause interference, and
2. This device must accept any interference, including interference that may cause undesired operation of the device.

[www.hetronic.com](http://www.hetronic.com)



© 2020 Hetronic

All rights reserved. No part of this publication may be reproduced, transmitted, transcribed, stored in a retrieval system, or translated into any language in any form by any means without the written permission of Hetronic.

Technical information subject to change without notice.

Hetronic reserves the right to discontinue, make changes to, and add improvements upon its products at any time without public notice or obligation. Hetronic disclaims liability for any claims or damages, whether regarding property, personal injury or death arising out of the use of unauthorized replacement parts or service.

## Appendix A

### Definition of terms

The following terms are used throughout the ERGO S User Manual and may be unfamiliar to some operators.

Term	Definition
baud rate	The transmitting speed measured in bits per second.
hamming distance	A measurement of data transmission safety. The amount of failures in the data stream which has to occur during the transmission in order to create a wrong signal. A low hamming distance means that the test is not very sensitive to data transmission errors and could potentially be unsafe. A high hamming distance means that the system is very sensitive and could potentially be unreliable due to potential noise interference.

## Appendix B

### B.1 Operator Safety Basics

Before starting your shift, you should make sure that the equipment has a current inspection certificate and that the necessary inspections and risk assessment checks have been carried out and are up to date. Also, the equipment must be operated in accordance with the manufacturer's instructions.

Furthermore, it is of utmost importance that you know that **YOU are primarily responsible for YOUR OWN health and safety**. Wear appropriate Personal Protective Equipment and make sure that you have had all the necessary training to operate the equipment. The following basic safety precautions must be adhered to at all times:

1. Transmitter switches must never be mechanically blocked ON or OFF for any motion. When not in use the transmitter must be turned off. A safe and secure storage space should be provided for the transmitter unit and the unit should always be placed there when not in use. This precaution will prevent unauthorized people from operating the crane. Receivers must be removed from the equipment when it is unlikely that it will be used for a period of time, and properly stored.
2. All defective or missing safety equipment, mechanical or electrical defects must be reported to the supervisor without delay. Operation must not continue until all required repairs are completed. Any changes to the condition of the remote or equipment must be recorded and communicated to or made accessible by the following operators on shift.
3. Ensure that there is nobody in the path of the travel of the equipment. If there is, stop and sound the alarm before proceeding.
4. When leaving the equipment area for any reason, switch off the transmitter, remove the USB Key and store it in a safe and secure place to prevent unauthorized operation.
5. Do not allow any unauthorized person to operate the transmitter at any point.
6. Do not operate the transmitter at a distance where the equipment and all surrounding objects are not visible. Make sure that your view is not obstructed.
7. Do not attempt to override any of the safety features built into the Radio Remote Control.
8. Put rechargeable batteries on charge at the end of each shift.
9. Use protective gloves when surface temperature of unit exceeds 58°C (136°F) as per IEC 62368-1:2014.

### B.2 Safety Checklist

The following checklist provides general safety guidelines for radio control operation of equipment by fully qualified and trained operators. These recommendations do not take precedence over any of the following requirements relating to cranes, hoists, lifting devices or other equipment which use or include Hetronic products:

- Instructions, manuals, and safety warnings of the manufacturers of the equipment where Hetronic products are used,
- Plant safety rules and procedures of the employers and the owners of the facilities where the Hetronic products are being used,
- Occupational Health and Safety Administration (OSHA) regulations,
- Safety standards and practices for the industries in which Hetronic products are used.

Transmitter Start-up and Safety Checklist		
1	Are batteries fully charged?	
2	Are all switch labels clear and legible?	
3	Is the transmitter free from cracks and damages?	
4	Are the battery enclosures free from cracks and damages?	
5	Is the STOP function working as it should be?	
6	Is the correct USB Key being used?	
7	Has each function of the transmitter been tested independently to ensure the equipment is responding correctly?	
8	Is the TFT free from cracks, deep scratches and damages?	
9	Is there any debris inside the USB port which will prevent the USB Key from being inserted /functioning properly?	
10	Are the Status LEDs on the transmitter clearly visible?	
11	Are the charger and plug in good working condition?	
12	Is the cable control cable (where applicable) free from kinks and damages?	

**B.3 ERGO S Variants and Current Rating**

**7169WXYZ.A**

W		X		Y		Z	
1	MFS	1	No TFT	1	One Step	1	Blank
2	Half Duplex	2	TFT	2	Two Step	2	With JS
3	Full Duplex					3	With SS

The table on the following page shows how the item number of an ERGO S unit is broken down and explains what each digit refers to with regards to different features available on the ERGO S.

Note: The suffix '.A' denotes version number, 'JS' refers to 'Joystick' and 'SS' denotes 'Selector Switch'.

Item Number	Description	W			X		Y		Z			Current Rating
		MFS	HD	FD	No TFT	TFT	One Step	Two Step	Blank	With JS	With SS	
71691010.A	ERGO S MFS 2G4 V1 W/O TFT	✓			✓		✓		✓			90mA
71691012.A	ERGO S MFS 2G4 V1 W/O TFT + SS	✓			✓		✓				✓	125mA
71691020.A	ERGO S MFS 2G4 V2 W/O TFT	✓			✓			✓	✓			90mA
71691022.A	ERGO S MFS 2G4 V2 W/O TFT + SS	✓			✓			✓			✓	125mA
71691110.A	ERGO S MFS 2G4 V1 W. TFT	✓				✓	✓		✓			180mA
71691111.A	ERGO S MFS 2G4 V1 W. TFT + JS	✓				✓	✓			✓		200mA
71691112.A	ERGO S MFS 2G4 V1 W. TFT + SS	✓				✓	✓				✓	215mA
71691120.A	ERGO S MFS 2G4 V2 W. TFT	✓				✓		✓	✓			180mA
71691121.A	ERGO S MFS 2G4 V2 W. TFT + JS	✓				✓		✓		✓		200mA
71691122.A	ERGO S MFS 2G4 V2 W. TFT + SS	✓				✓		✓			✓	215mA
71692010.A-434	ERGO S V1 W/O TFT		✓		✓		✓		✓			130mA
71692020.A-434	ERGO S V2 W/O TFT		✓		✓			✓	✓			130mA
71692110.A-434	ERGO S V1 W. TFT		✓			✓	✓		✓			200mA
71692111.A-434	ERGO S V1 W. TFT + JS		✓			✓	✓			✓		220mA
71692112.A	ERGO S V1 W. TFT + SS		✓			✓	✓				✓	235mA
71692120.A-434	ERGO S V2 W. TFT		✓			✓		✓	✓			200mA
71692121.A-434	ERGO S V2 W. TFT + JS		✓			✓		✓		✓		220mA
71692122.A	ERGO S V2 W. TFT + SS		✓			✓		✓			✓	235mA
71693110.A-434	ERGO S V1 FD W. TFT			✓		✓	✓		✓			210mA
71693111.A-434	ERGO S V1 FD W. TFT + JS			✓		✓	✓			✓		260mA
71693112.A	ERGO S V1 FD W. TFT + SS			✓		✓	✓				✓	245mA
71693120.A-434	ERGO S V2 FD W. TFT			✓		✓		✓	✓			210mA
71693121.A-434	ERGO S V2 FD W. TFT + JS			✓		✓		✓		✓		260mA
71693122.A	ERGO S V2 FD W. TFT + SS			✓		✓		✓			✓	245mA



## Appendix C

### C.1 Spare Parts

Keep the safety instructions for future reference. Always download the User Manual instructions from our website for the latest version available.

Refer to the online web shop for respective part numbers of any parts that may need replacement:

<https://shop.hetronic.com/mt/en/home>

**NOTE:** Any service/maintenance work and replacement of parts must be carried out by an authorized dealer or service centre specified by Hetronic.